

Basic principles of exciter-technology

Table of contents

1. Functionality of the VISATON Exciter
2. Mounting the VISATON Exciter
3. Advantages and disadvantages of the exciter-technology
4. Frequently asked questions (FAQ)

1. Functionality of the VISATON Exciter

An exciter, also known as bodyshaker, is basically a loudspeaker without a membrane. It mainly consists of 3 components: the oscillating mass (1), the contact pins (2) to connect to the amplifier, and the mounting plate (3) to hook up to the surface to be excited.



1. Oscillating mass
2. Contact pins
3. Mounting plate

By applying a voice- or music signal to the contact pins, the oscillating mass starts shaking with the frequency of the applied signal. This oscillation is transmitted to the mounting plate and from there on to the surface the exciter sticks to. Thus, the excited surface will emit the voice- or music signal.

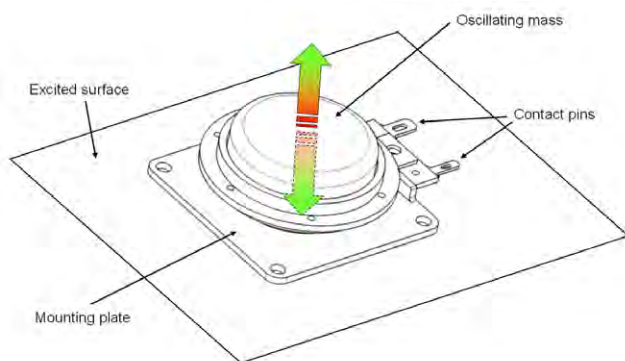

The functionality of an exciter is therefore pretty similar to the functionality of a conventional loudspeaker. However, there are some differences in how the sound is emitted. The excited surface is, compared to a lightweight cone membrane, very large and heavy, and thus unable to oscillate coherently. That means, not every point of the surface moves into the same direction with the same amplitude at the same time. The exciter generates a bending wave which propagates towards the edge of the excited plate, where it is reflected back towards the exciter. To illustrate this behavior, one can imagine a stone thrown into a basin of water. From the point where the stone hits the surface of the water, a circular bending wave propagates towards the seam of the basin, where it is reflected. The original wave and the reflected wave interfere with each other, causing a chaotic wave-pattern on the water surface. The same applies to the excited surface: The original wave from the exciter interferes with the reflected waves from the edges of the plate, resulting in an incoherent emission of sound. This incoherent sound emission is the main reason for the very wide, uniformly distributed sound field of an excited surface. As one can easily imagine, the quality of the reproduced music- or voice signal is strongly dependent on the characteristics of the excited surface, such as material, shape and dimensions.

2. Mounting the VISATON Exciter

Mode of mounting

Depending on the type of exciter that is used, the exciter is attached to the surface by means of gluing and/or screwing. Generally, a clean and even surface is required. The whole mounting plate of the exciter is to be seated solidly onto the excited surface. For gluing an exciter onto a surface, two component glues, silicone or a long-term stable double-sided adhesive tape suit best. The consistency of the surface must always be taken into account when choosing the right glue.

Exciter which provide an inserted nut instead of the flat mounting plate, require a matching threaded bolt for installation, that needs to be attached firmly to the excited surface.

Position of mounting

In many cases, a mounting position slightly off-center of the excited surface gives good results. Because the acoustical results are strongly dependent on material properties and the shape of the excited surface, listening tests and measurements are inevitable to determine the optimal mounting position. For testing different mounting positions, a standard double-sided adhesive tape can be used. In order to test positions at the rear side of a surface that are difficult to access, the exciter can provisionally be mounted at the equivalent position on the front side of the surface, which doesn't affect the sound output.

Materials and shapes of the excited surface

- The larger the excited plate, the better the reproduction of low frequencies, the sound output is more voluminous
- The smaller the excited plate, the weaker the reproduction of low frequencies, the sound output is less voluminous
- The efficiency factor (sound pressure level compared to input power) decreases with increasing weight of the excited plate. The plate therefore is preferably lightweight
- The plate ought to be rigid
- The plate should consist of a non-magnetic material. The exciter contains a permanent magnet which would cause a harmful pre-tension to the suspension of the exciter if attached to a magnetic plate
- The appearance of the excited surface has a great impact on the sound output. Devices with few reinforcing structures and large surfaces qualify best. Anyways, many different types of devices and surfaces are suitable for the use of exciters. In any case, measurements and listening tests are the most reliable methods to determine the best operating surface for an exciter

Wiring

When wiring up an exciter, the cables must be routed in such a manner, that they cannot cause any noise by vibrating or rattling against the surface. If necessary, the wires can be foam-padded to avoid such noise.

3. Advantages and disadvantages of the exciter-technology

Advantages

- „invisible“ loudspeaker – no interference with design issues
- perfect protection against environmental influences (weather, water, cleaning agents)
- perfect protection against vandalism
- easy installation
- capable of high quality sound output and a wide sound dispersion angle

Disadvantages

- low efficiency factor compared to standard loudspeakers (more output power from the amplifier required)
- Devices that are able to touch the excited surface can cause disturbing noise
- acoustics strongly dependent on material, dimensions and shape of the excited plate

4. Frequently asked questions (FAQ)

– *Is a special amplifier required in order to drive a VISATON Exciter?*

No. Every VISATON Exciter can be hooked up to a conventional HiFi amplifier

– *Are there any recommendations regarding a suitable double-sided adhesive tape?*

The adhesive tape should be chosen depending on the surface properties at the desired location of the exciter. Manufacturers like 3M have a large variety of suitable tapes in stock

– *Are special lead wires required?*

No. Conventional loudspeaker cables can be used

– *Which materials suit best as an excited plate?*

In the following, some examples of materials are listed that give a good sound output:

- sandwich panels with honeycomb structures (e.g. hexagon-structure)
- thin particle boards (e.g. HDF / MDF)
- plexiglass plates
- glass plates / windows (even heavy duty types like compound windowpanes)
- panels for suspended ceilings
- high density foam plates
- dry wall panels
- fiberglass / fiberglass-reinforced plastic

– *Why does VISATON provide no information about frequency response, transmission range or efficiency factor of the exciters?*

These parameters are dependent on the material, the dimensions and the shape of the excited plate, and therefore hardly predictable. To give an example, the frequency response of a VISATON EX 60 S exciter, mounted onto two different types of plates, is depicted below. As can be seen in the graph, a harmonic and balanced frequency response over a wide spectrum can be obtained with both plates. Even music playback with a decent sound quality can be conducted successfully with such an arrangement.

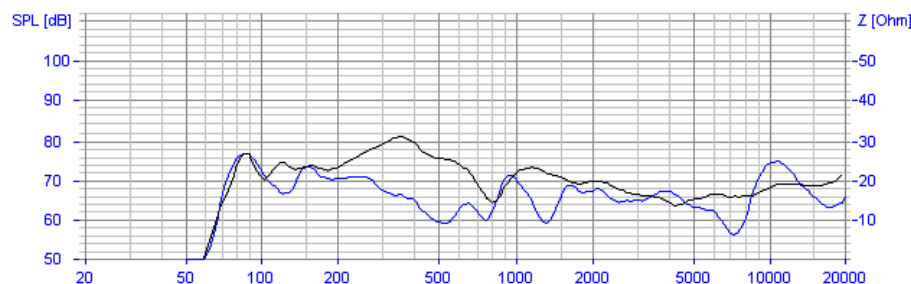

frequency response (1 W / 1 m)

black = HDF board (690 x 660 x 4 mm)

blue = MDF board (1200 x 800 x 19 mm)

– *How does an exciter-equipped plate behave when suspended close to a wall (like a painting)?*

If mounted close to a wall, especially the low frequencies cancel out due to the bilateral sound output of the excited plate. The rearward sound is reflected by the wall and, because of the negative polarity, subtracted from the front-side sound output. The closer the excited plate is located to a wall, the weaker the sound output at low frequencies.

EX 30 S

Art. No. 4532 – 8 Ω



Technische Daten / Technical Data

Belastbarkeit Power	10 W ^{*)}
Impedanz Impedance	8 Ω
Schwingspulen­durchmesser Voice coil diameter	20,5 mm Ø
Anschluss Terminal	4,8 x 0,8 / 2,8 x 0,8 mm
Gewicht netto Net weight	40 g

^{*)} Maximale Langzeitleistung nach DIN EN 60268-5
Maximum long-term power according to DIN EN 60268-5

Elektrodynamischer Exciter zur Anregung von Platten zu Biege­wellenschwingungen. Die Befestigung des Exciters auf der Oberfläche der anzuregenden Platte kann durch Kleben oder Schrauben erfolgen.

Anwendungsmöglichkeiten

Signalausgabe in Anwendungen aller Art, bei denen aus Design­gründen oder zum Schutz vor Umwelteinflüssen oder Vandalismus keine sichtbaren Lautsprecher verbaut werden können.

Electro dynamical exciter for stimulating bending waves on plates. The unit can be attached to the surface of the plate by gluing or screwing.

Typical applications

Signal output in every application where normal speakers can not be installed for optical reasons or for protection against environment conditions or vandalism.

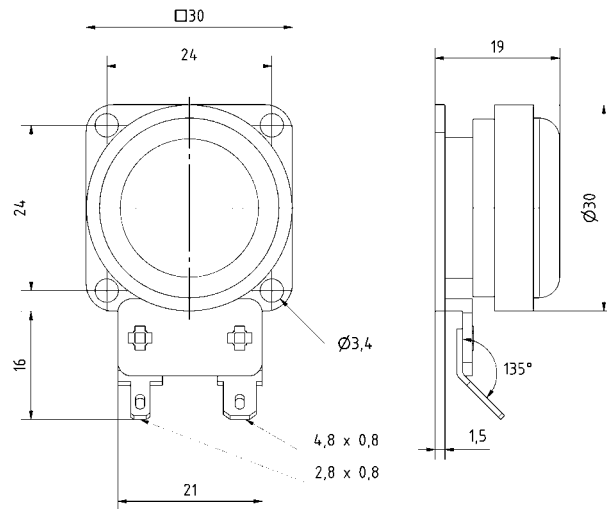

EX 30 S
01.09.2015

EX 45 S

Art. No. 4503 – 4 Ω

Art. No. 4501 – 8 Ω

Elektrodynamischer Exciter zur Anregung von Platten zu BiegeWellenschwingungen. Die Befestigung des Exciters auf der Oberfläche der anzuregenden Platte kann durch Kleben oder Schrauben erfolgen.

Anwendungsmöglichkeiten: Signalausgabe in Anwendungen aller Art, bei denen aus Designgründen oder zum Schutz vor Umwelteinflüssen oder Vandalismus keine sichtbaren Lautsprecher verbaut werden können.

Electro dynamical exciter for stimulating bending waves on plates. The unit can be attached to the surface of the plate by gluing or screwing.

Typical applications: Signal output in every application where normal speakers can not be installed for optical reasons or for protection against environment conditions or vandalism.

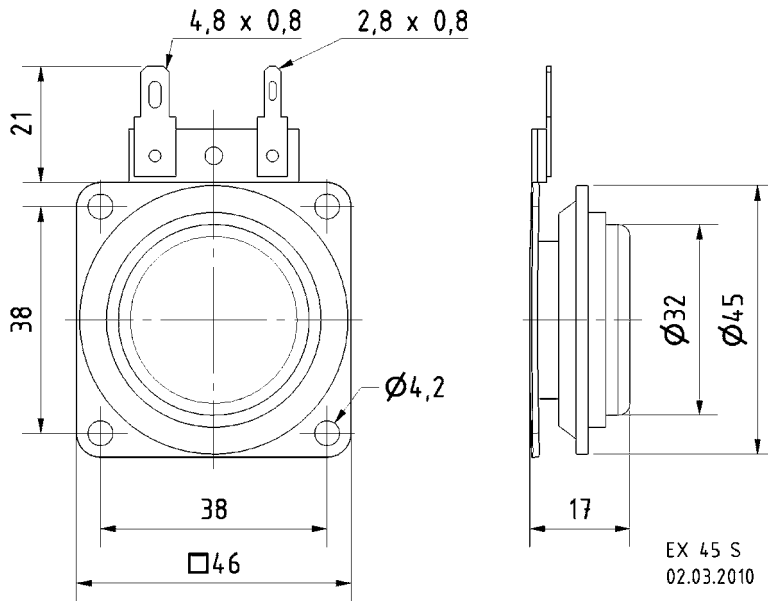

Technische Daten / Technical Data

Belastbarkeit Power	10 W ^{*)}
Impedanz Impedance	4 Ω / 8 Ω
Schwingspulendurchmesser Voice coil diameter	25,4 mm Ø
Gewicht netto Net weight	60 g

^{*)} Maximale Langzeitleistung nach DIN EN 60268-5
Maximum long-term power according to DIN EN 60268-5

EX 60 S

Art. No. 4536 – 4 Ω

Art. No. 4506 – 8 Ω



Technische Daten / Technical Data

Belastbarkeit Power	25 W *)
Impedanz Impedance	4 Ω / 8 Ω
Schwingspulendurchmesser Voice coil diameter	32,5 mm Ø
Gewicht netto Net weight	0,12 kg

*) Maximale Langzeitleistung nach DIN EN 60268-5
Maximum long-term power according to DIN EN 60268-5

Elektrodynamischer Exciter zur Anregung von Platten zu Biegewellenschwingungen. Die Befestigung des Exciters auf der Oberfläche der anzuregenden Platte kann durch Kleben oder Schrauben erfolgen.

Anwendungsmöglichkeiten: Signalausgabe in Anwendungen aller Art, bei denen aus Designgründen oder zum Schutz vor Umwelteinflüssen oder Vandalismus keine sichtbaren Lautsprecher verbaut werden können.

Eigenschaften:

- erfüllt Anforderungen der EN 60068-2-14 (Temperaturwechsel, zyklisch: -40 °C/+80 °C)
- erfüllt Anforderungen der EN 61373 (Schwingen, Schocken: Kategorie 1/Klasse B)

Electro dynamical exciter for stimulating bending waves on plates. The unit can be attached to the surface of the plate by gluing or screwing.

Typical applications: Signal output in every application where normal speakers can not be installed for optical reasons or for protection against environment conditions or vandalism.

Attributes:

- Complies with standard EN 60068-2-14 (change of temperature, cyclic: -40 °C/+80 °C)
- Complies with standard EN 61373 (vibration, shock: category 1/class B)

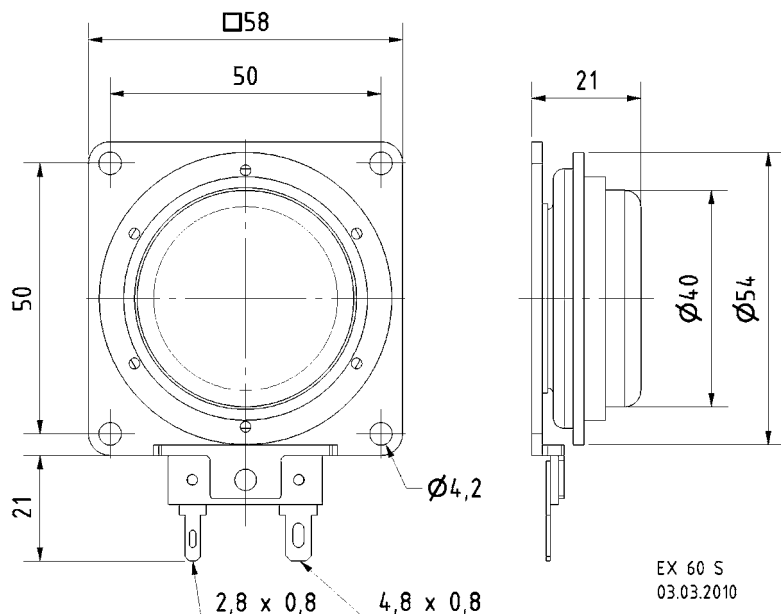

EX 60 S
03.03.2010

Pad EX 60 S

Art. No. 4556



Klebepad zur Befestigung des Exciters EX 60 S auf glatten Oberflächen.
Typ: 3M VHB 4919F

Gluing pad for fitting the EX 60 S exciters on flat surfaces.
Type: 3M VHB 4919F

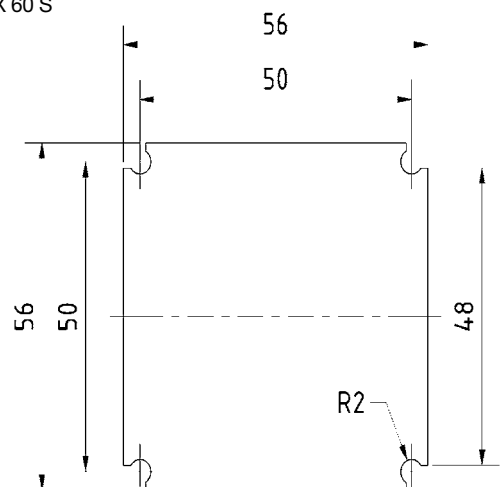

Pad EX 60 S
04.09.2017

Elektrodynamischer Exciter zur Anregung von Platten zu BiegeWellenschwingungen. Die Befestigung des Exciters auf der Oberfläche der anzuregenden Platte kann durch Kleben oder Schrauben erfolgen.

Eigenschaften:

- erfüllt Anforderungen der EN 60068-2-14 (Temperaturwechsel, zyklisch: -40 °C/+80 °C)
- erfüllt Anforderungen der EN 61373 (Schwingen, Schocken: Kategorie 1/Klasse B)

Anwendungsmöglichkeiten: Signalausgabe in Anwendungen aller Art, bei denen aus Designgründen oder zum Schutz vor Umwelteinflüssen oder Vandalismus keine sichtbaren Lautsprecher verbaut werden können.

Zubehör: Pad EX 60 R (Art. No. 4557)

Electro dynamical exciter for stimulating bending waves on plates. The unit can be attached to the surface of the plate by gluing or screwing.

Attributes:

- Complies with standard EN 60068-2-14 (change of temperature, cyclic: -40 °C/+80 °C)
- Complies with standard EN 61373 (vibration, shock: category 1/class B)

Typical application: Signal output in every application where normal speakers can not be installed for optical reasons or for protection against environment conditions or vandalism.

Accessories: Pad EX 60 R (Art. No. 4557)

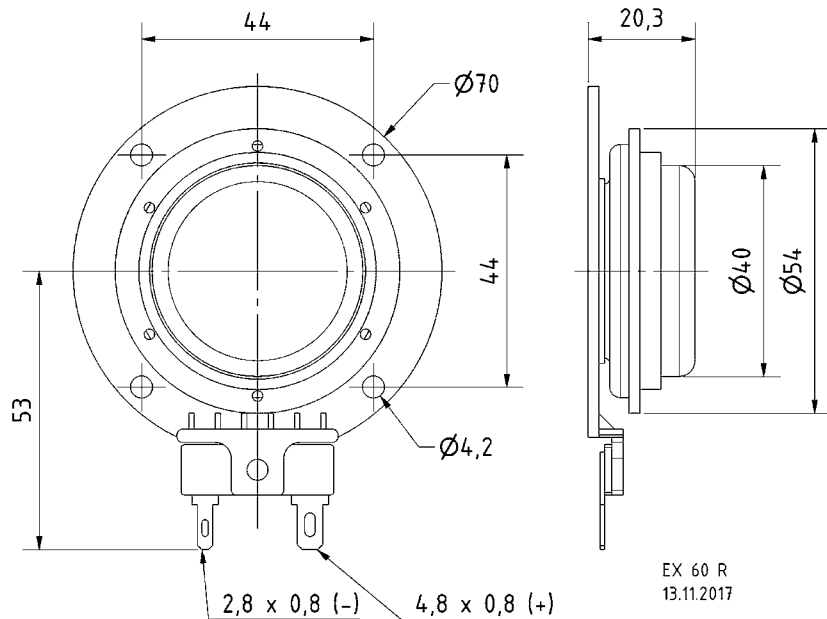

Technische Daten / Technical Data

Belastbarkeit Power	25 W *)
Impedanz Impedance	8 Ω
Schwingspulendurchmesser Voice coil diameter	32,6 mm Ø
Anschlüsse Connections	4,8 x 0,8 mm (+) 2,8 x 0,8 mm (-)
Gewicht netto Net weight	0,125 kg

*) Maximale Langzeitleistung nach DIN EN 60268-5
Maximum long-term power according to DIN EN 60268-5

Klebepad zur Befestigung des Exciters EX 60 R auf glatten Oberflächen.
Typ: 3M VHB 4919F

Gluing pad for fitting the EX 60 R exciters on flat surfaces.
Type: 3M VHB 4919F

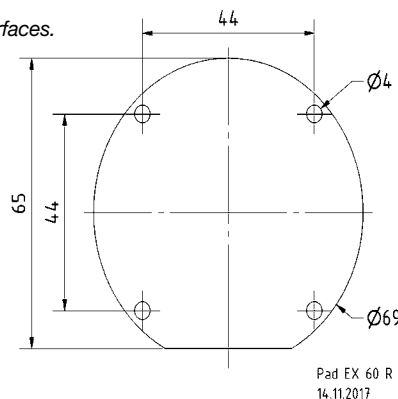

Pad EX 60 R
Art. No. 4557



EX 80 S

Art. No. 4541 – 8 Ω



Technische Daten / Technical Data

Belastbarkeit Power	50 W *)
Impedanz Impedance	8 Ω
Schwingspulendurchmesser Voice coil diameter	35,6 mm Ø
Anschlüsse Connections	4,8 x 0,8 mm (+) 2,8 x 0,8 mm (-)
Gewicht netto Net weight	0,162 kg

*) Maximale Langzeitleistung nach DIN EN 60268-5
Maximum long-term power according to DIN EN 60268-5

Elektrodynamischer Exciter zur Anregung von Platten zu Biegewellenschwingungen. Die Befestigung des Exciters auf der Oberfläche der anzuregenden Platte kann durch Kleben oder Schrauben erfolgen.

Anwendungsmöglichkeiten: Signalausgabe in Anwendungen aller Art, bei denen aus Designgründen oder zum Schutz vor Umwelteinflüssen oder Vandalismus keine sichtbaren Lautsprecher verbaut werden können.

Electro dynamical exciter for stimulating bending waves on plates. The unit can be attached to the surface of the plate by gluing or screwing.

Typical application: Signal output in every application where normal speakers can not be installed for optical reasons or for protection against environment conditions or vandalism.

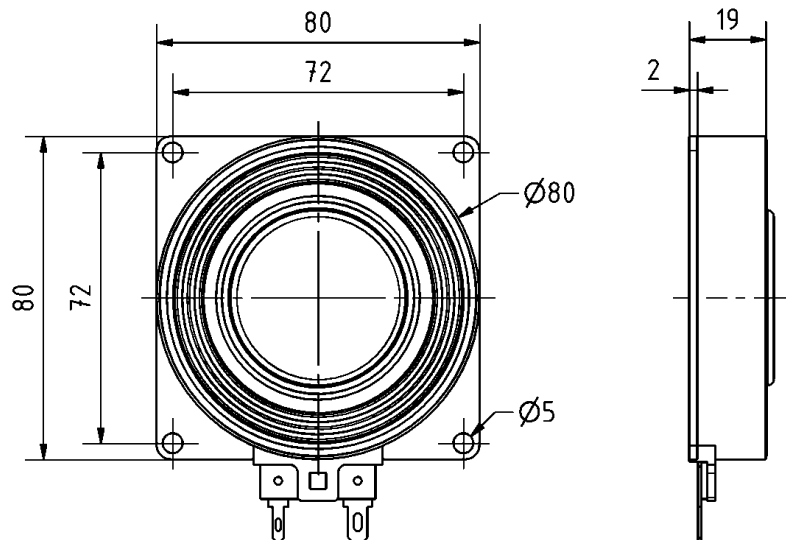

EX 80 S

28.08.2015